



***MGM Industries***

*SIMULATION PERFORMANCE &  
SOLAR HEAT GAIN REPORT*

*“8010”  
Double Hung*

*NCTL-110-10910-01*

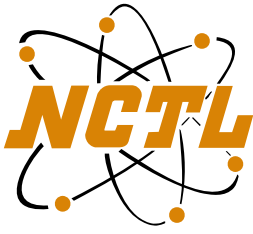

# NATIONAL CERTIFIED TESTING LABORATORIES

FIVE LEIGH DRIVE • YORK, PENNSYLVANIA 17406 • TELEPHONE (717) 846-1200  
FAX (717) 767-4100  
www.nctlinc.com

## **Simulation Performance, Solar Heat Gain Coefficient, Visible Transmittance and Condensation Resistance Calculation Report**

**REPORT NO:** NCTL-110-10910-01  
**SIMULATION DATE:** 09/20/07  
**REPORT DATE:** 09/20/07

**Client:** MGM Industries  
287 Freehill Road  
Hendersonville, TN 37075

**Product Line:** MGM Industries' Series "8010" Double Hung

**Specification:** NFRC 100-2004: "Procedure for Determining Fenestration Product U-Factors".  
NFRC 200-2004: "Procedure for Determining Fenestration Product Solar Heat  
Gain Coefficients and Visible Transmittance at Normal Incidence".  
NFRC 500-2004: "Procedure for Determining Fenestration Product  
Condensation Resistance Values".  
Therm 5.x / Window 5.x NFRC Simulation Manual (Approved at test date)

**Procedures  
and  
Compliance:** All U-factor, Solar Heat Gain Coefficients, Visible Transmittance and  
Condensation Resistance values were calculated using the following  
characteristics: a default value of 0.30 solar absorptance for all products  
other than window glazed wall and sloped glazing which have a solar  
absorptance of 0.50. The best glazing option was used as the configuration  
for SHGC and VT specialty products table. NCTL is a NFRC accredited  
simulation laboratory and this simulation was conducted in full compliance  
with NFRC requirements. This report does not constitute an opinion or  
endorsement by the laboratory. Ratings values included in this report are for  
submittal to an NFRC-licensed IA and are not meant to be used directly for  
labeling purposes. Only those values identified on a valid Certification  
Authorization Report (CAR) by an NFRC accredited Inspection Agency (IA) are  
to be used for labeling purposes. Rounding per IEEE/ASTM SI 10-1997  
except section 5.4.1.3.

### **PRODUCT LINE DESCRIPTION**

**General:** The product line modeled is MGM Industries' Series "8010" Double Hung.

Model Size Simulations: 1200mm x 1500mm (47.244" x 59.055")

Note: All product drawings are included in Attachment A.

**Weatherseals:**

Location	Weather Seal Description
Head	(1) single strips of weather-strip
Top Jamb	(3) single strips of weather-strip
Bottom Jamb	(3) single strips of weather-strip
Meeting Rail	(2) single strips of weather-strip
Sill	(1) single strip of weather-strip and Bulb Seal

**Reinforcement:** Not applicable.

**Finish:** Vinyl

**Dividers:** Where applicable, dividers were not modeled because the gap between dividers and lites were greater than 3mm. For Solar Heat Gain and Visual Light Transmittance default dividers less than 1" and greater or equal to 1" and default patterns were used for simulations.

**Group Leaders:** The following group leaders are actual simulated individual products per NFRC 4.2.4 and the NFRC Technical Interpretations where applicable. All remaining individual products' U-factors in the corresponding groups are represented by the group leader's U-factor.

**COG Group Leader:** Individual products which differ from another (base) individual product in glazing tint and/or obscurity (including obscure glass, fritted glass, and wired glass) only may be assumed to have the same U-factor as the base product unless this change is associated with a change in coating properties.

**COG Group Leader:**

Glazing ID	Glazing Description	U <sub>COG</sub>
001	AFG TiAC#36 / Air / AFG Clear	0.481*
005	AFG TiAC#36 / Air / AFG Clear	0.298*

\* Group Leader

**Modeling Assumptions and Comments Deemed Important:****Sealing Rules:**

All cavities that are opened to the exterior within a frame section shall be modeled according to ISO 15099, Section 6.7.1, which states that cavities greater than 2mm but equal to or less than 10 mm shall be modeled as "slightly ventilated air cavities". For physical testing purposes the product is sealed at the inside surface with tape or equivalent to prevent air infiltration. Air cavities created by this sealing technique must be simulated with the standard NFRC "Frame Cavity" material. If cavities on the frame are sealed (covered) to the surround panel with tape or equivalent, those cavities are also filled with NFRC "Frame Cavity" material within the simulation model. If the frame is not covered or sealed, those areas are left hollow or opened within the simulation model.

**Continuous elements:**

All elements continuous within the product line are identified from the Bill-of-Materials and detailed drawings via the referenced dimensions and cut lengths as compared to the overall size of the product.

**Component Area and Frame Heights:**

Frame heights, calculated areas, area weighted values for U-factor, SHGC, and VT, and center –of-glazing are located in approved NFRC simulation programs for all individual products.

**General Notes:**

The Condensation Resistance results obtained from this procedure are for controlled laboratory conditions and do not include the effects of air movement through the specimen, solar radiation, and the thermal bridging that may occur due to the specific design and construction of the fenestration system opening.

**Modeling assumptions:**

The product was modeled with a nominal 1" x 4" wood stud attached to the exterior flange.

**Miscellaneous assumptions:**

1. The screen extrusions were not modeled.
2. All radii are simulated at angles.
3. Any spacer simulated using a spacer system from the Frame Spacer Library match the required configurations for this manufacturer's spacer system.
4. The modeling was performed in accordance with the manufacturer's assembly drawing from a DXF file.

**Specialty Products Table:** The specialty products method allows the manufacturer to determine the overall product SHGC and VT for any glazing option. The center of glass SHGC and/or VT must be determined using WINDOW 5.2. The method gives overall product SHGC and VT indexed on center of glass properties.

SHGC	No Dividers	Dividers <1"	Dividers ≥1"
0.00	0.002	0.005	0.008
1.00	0.765	0.684	0.608

VT	No Dividers	Dividers <1"	Dividers ≥1"
0.00	0.000	0.000	0.000
1.00	0.763	0.679	0.600

$$SHGC = SHGC_0 + SHGC_{COG} (SHGC_1 - SHGC_0)$$

$$VT = VT_0 + VT_{COG} (VT_1 - VT_0)$$

**NCTL Therm Section Filename Methodology**

Filename Codes Example: CU_HD2_003.THM	
CU	Spacer (Intercept)
HD	Frame Section (Head)
2	Glass Size (2.5mm)
003	Glazing ID #3

***Individual Product Descriptions and Model Size Matrix of U-Factors, SHGC, VT & CR***

*All U-factors are given in BTU/HR/ft<sup>2</sup>/°F*

Product Description	Product Number	Pane ID (Exterior)	Pane ID (Interior)	Pane Thickness (Exterior)	Pane Thickness (Interior)	Gap	Gap Fill	% of Gap Fill	Emissivity Surface 2	Emissivity Surface 3	U-factor C-O-G	SHGC C-O-G	VT C-O-G	Spacer	Grid Type	Tint	U-factor	Condensation Resistance	Solar Heat Gain Coefficient (ND)	Visual Transmittance (ND)	Solar Heat Gain Coefficient (<1")	Visual Transmittance (<1")
CLR_SS_AIR	<b>001</b>	885	885	0.098	0.098	0.553	AIR				0.48	0.80	0.83	CU-D	N,G	CL	<b>0.46</b>	<b>43</b>	<b>0.61</b>	<b>0.63</b>	<b>0.55</b>	<b>0.56</b>
CLR_DS_AIR		887	887	0.118	0.118	0.514	AIR				0.48	0.79	0.82	CU-D	N,G	CL	<b>0.46</b>	<b>43</b>	<b>0.60</b>	<b>0.63</b>	<b>0.54</b>	<b>0.56</b>
TiAC36#3_SS_AIR	<b>002</b>	885	964	0.098	0.098	0.553	AIR			0.034	0.30	0.47	0.69	CU-D	N,G	LE	<b>0.33</b>	<b>54</b>	<b>0.36</b>	<b>0.53</b>	<b>0.32</b>	<b>0.47</b>
TiAC36#2_SS_AIR		964	885	0.098	0.098	0.553	AIR	0.034			0.30	0.37	0.69	CU-D	N,G	LE	<b>0.33</b>	<b>54</b>	<b>0.28</b>	<b>0.53</b>	<b>0.25</b>	<b>0.47</b>
TiAC36#3_DS_AIR		887	965	0.118	0.118	0.514	AIR			0.034	0.29	0.46	0.68	CU-D	N,G	LE	<b>0.33</b>	<b>54</b>	<b>0.35</b>	<b>0.52</b>	<b>0.32</b>	<b>0.46</b>
TiAC36#2_DS_AIR		965	887	0.098	0.098	0.514	AIR	0.034			0.29	0.37	0.68	CU-D	N,G	LE	<b>0.33</b>	<b>54</b>	<b>0.28</b>	<b>0.52</b>	<b>0.25</b>	<b>0.46</b>

A baseline product test in accordance with the "NFRC 102: Test Procedure for Measuring the Steady-State Thermal Transmittance of Fenestration Systems" is required in order to validate the "Model Size Matrix of U-Values" as previously indicated. Per Section 1.4.3 of NFRC 100-2004, "the baseline product is the individual product selected for validation testing". **The individual product selected as the baseline product shall be the lowest simulated individual product or an individual product having a simulated U-factor within 0.60 W/(m<sup>2</sup>\*K) (0.10 BTU/HR/ft<sup>2</sup>/°F) or 20% of the listed lowest simulated U-factor.**

**Note:**

1. For lowest U-factor listings where multiple individual products are shown, validation testing can be conducted on any of the configurations listed.
2. Actual simulated individual products are required for product line validation testing.
3. All individual products in the product line were simulated using the approved NFRC THERM program.

For the purposes of validation testing, production line units and sizes shall be used to represent the baseline product. Per the client, the model size is manufactured as part of their product line; therefore the previously listed model size can be used for baseline product validation testing.

Copies of this report and the detailed product drawings will be retained by NCTL for a period of four (4) years. This report may not be reproduced, except in full, without the approval of NCTL. The results only to the fenestration product simulated. The attached diskette(s) contain(s) all required NFRC data and software files.

**NATIONAL CERTIFIED TESTING LABORATORIES**

  
  
DIGITAL SIGNATURE

**CHRISTIAN J. MITCHELL**

Simulator

  
  
DIGITAL SIGNATURE

**STEVEN H. COBLE**

NFRC Accredited Simulator

Simulator-In-Responsible-Charge

**Report Log**

**Product Line:** *MGM Industries' Series "8010" Double Hung*

**Date:**  
**09/20/07** - *Original Report issued to MGM Industries and Inspection Agency*

**NFRC CODES**

<b>Door</b>	
<b>Code</b>	<b>Description</b>
EM	Embossed
FL	Flush
LF	Full Lite
LH	1/2 - Lite
LQ	1/4 - Lite
LT	3/4 - Lite
N	Not Applicable
RP	Raised Panel

<b>Grid</b>	
<b>Code</b>	<b>Description</b>
G	Grids between the glass
N	No Muntins
S	Simulated Divided Lites
T	True Muntins

<b>Sealant</b>	
<b>Code</b>	<b>Description</b>
D	Dual Seal Spacer System
N	Not Applicable
S	Single Seal Spacer System

<b>Gap Fill</b>	
<b>Code</b>	<b>Description</b>
AIR	Air
AR3	Argon/Krypton/Air Mixture
ARG	Argon
KRY	Krypton
N	Not Applicable

<b>Glass Tint</b>	
<b>Code</b>	<b>Description</b>
AZ	Azurlite
BG	Blinds between the Glazing
BL	Blue
BZ	Bronze
CL	Clear
DV	Dynamic Glazing (Variable)
DY	Dynamic Glazing (Non-Variable)
EV	Evergreen
GC	Gold (reflective coating)
GD	Gold
GR	Green
GY	Gray
LE	Low 'e' Coating
OT	Other (use comment field)
RC	Solar or Reflective Coating
RG	Roller shades between Glazing
RS	Silver (reflective coating)
SF	Suspended Polyester Film
SR	Silver

<b>Spacer</b>		
<b>Code</b>	<b>Type</b>	<b>Definition</b>
A1-D	Aluminum	Aluminum spacer system - dual sealed.
A1-S	Aluminum	Aluminum spacer system - single sealed.
A2-D	Aluminum (thermally-broken)	Thermally improved aluminum spacer system - dual sealed.
A2-S	Aluminum (thermally-broken)	Thermally improved aluminum spacer system - single sealed.
A3-D	Aluminum-reinforced polymer	Polymer spacer material with aluminum substance - dual sealed.
A3-S	Aluminum-reinforced polymer	Polymer spacer material with aluminum substance - single sealed.
A4-D	Aluminum/Wood	Composite spacer system of two materials - dual sealed.
A4-S	Aluminum/Wood	Composite spacer system of two materials - single sealed.
A5-D	Aluminum-reinforced butyl	Butyl spacer material with aluminum substrate - dual sealed.
A5-S	Aluminum-reinforced butyl	Butyl spacer material with aluminum substrate - single sealed.
A6-D	Aluminum/Foam/Aluminum	Two aluminum spacers separated by foam-type material - dual sealed
A6-S	Aluminum/Foam/Aluminum	Two aluminum spacers separated by foam-type material - single sealed
A7-D	Aluminum U-shaped	U-shaped spacer system embedded in sealant - dual sealed.
A7-S	Aluminum U-shaped	U-shaped spacer system embedded in sealant - single sealed.

<b>Spacer</b>		
<b>Code</b>	<b>Type</b>	<b>Definition</b>
A8-D	Aluminum-Butyl Composite	Exposed corrugated aluminum spacer with butyl - dual sealed.
A8-S	Aluminum-Butyl Composite	Exposed corrugated aluminum spacer with butyl - single sealed.
CS-D	Coated Steel	Coated Steel (galvanized or tinplated) - Dual seal
CS-S	Coated Steel	Coated Steel (galvanized or tinplated) - Single seal
CU-D	Coated Steel U-Shaped	Coated Steel (galvanized or tinplated) U-shaped spacer system embedded in sealant - Dual sealed
CU-S	Coated Steel U-Shaped	Coated Steel (galvanized or tinplated) U-shaped spacer system embedded in sealant - Single sealed
ER-D	EPDM Reinforced Butyl	EPDM reinforced butyl spacer system - dual sealed.
ER-S	EPDM Reinforced Butyl	EPDM reinforced butyl spacer system - single sealed.
FG-D	Fiberglass	Fiberglass - dual sealed.
FG-S	Fiberglass	Fiberglass - single sealed.
GL-S	Glass	Welded glass edge condition at glazing perimeter.
N	Not Applicable	
OF-D	Organic Foam	Organic-based foam spacer system - dual sealed.
OF-S	Organic Foam	Organic-based foam spacer system - single sealed.
P1-D	Polycarbonate- Butyl Composite	Exposed corrugated polycarbonate spacer with butyl - dual sealed.
P1-S	Polycarbonate- Butyl Composite	Exposed corrugated polycarbonate spacer with butyl - single sealed.
PU-D	Polyurethane foam	Polyurethane foam - dual sealed.
PU-S	Polyurethane foam	Polyurethane foam - single sealed.
S2-D	Steel (thermally-broken)	Stainless steel spacer with urethane thermal break - dual sealed.
S2-S	Steel (thermally-broken)	Stainless steel spacer with urethane thermal break - single sealed.
S3-D	Steel/Foam/Steel	Two steel spacers separated by foam-type material - dual sealed.
S3-S	Steel/Foam/Steel	Two steel spacers separated by foam-type material - single sealed.
S5-D	Steel reinforced butyl	Butyl spacer material with stainless steel substrate - dual sealed.
S5-S	Steel reinforced butyl	Butyl spacer material with stainless steel substrate - single sealed.
S6-D	Steel U-channel w/ thermal cap	U-shaped steel spacer system with a thermal cap - dual sealed.
S6-S	Steel U-channel w/ thermal cap	U-shaped steel spacer system with a thermal cap - single sealed.
SS-D	Stainless Steel	Stainless Steel - Dual Seal
SS-S	Stainless Steel	Stainless Steel - Single Sealed
SU-D	Stainless Steel U-Shaped	Stainless Steel U-shaped spacer system embedded in sealant - Dual sealed
SU-S	Stainless Steel U-Shaped	Stainless Steel U-shaped spacer system embedded in sealant - Single sealed
TP-D	Thermo-plastic	Thermo-plastic - dual sealed.
TP-S	Thermo-plastic	Thermo-plastic - single sealed.
TS-D	Thermo-plastic	Thermoplastic spacer with stainless steel substrate - dual-sealed
TS-S	Thermo-plastic	Thermoplastic spacer with stainless steel substrate - single-sealed
WD	Wood	Wood spacer system
ZF-D	Silicone Foam	Silicone foam spacer system - dual sealed.
ZF-S	Silicone Foam	Silicone foam spacer system - single sealed.
ZS-D	Silicone/Steel	Combination of two separate spacers: a steel spacer and silicone spacer - dual sealed.
ZS-S	Silicone/Steel	Combination of two separate spacers: a steel spacer and silicone spacer - single sealed.

***ATTACHMENT A***

***Product Drawings***

TEST SPECIMEN COMPLIES  
WITH THESE DETAILS.

ANY DEVIATION IS NOTED.

Bill of Materials Listing

Print Date: 07/10/07  
REPORT NO: NCTL-110-10910-1  
TEST DATE: 9/20/2007

Product: 8010 Type: DH

Assembly Code	Part #	Description	Qty	Height	Width	Unit Code	Vert Hor	Sub Assy	Add Color	Fixed Length	W/Nailing Fin
ASSCR1	8X1PH	Assembly Screw #1	4.00			EA		IA	N		8X1PH
ASSCR2	6X1/2TRUSS	Assy Screw #2	2.00			EA		IA	N		
ASSCR3	6AX1-1/4FH	Keeper Screw	4.00			EA		IA	N		6AX1-1/4FH
GLASS	1CL	Default Glass Type	1.00	3.6250	4.0000	SF		IA	N		1CL
GLSSPC	SWGG-9/16	Glass Spacer	2.00		4.0000	LI	W	IA	N		SWGG-9/16
GLSSPC	SWGG-9/16	Glass Spacer	2.00	3.6250		LI	H	IA	N		SWGG-9/16
HEADER	8022	Frame Top Extrusion	1.00		3.8750	LI	W	IA	Y		8022
KEEPER	3314	Keeper	2.00			EA		IA	N		3314
LATCH	TWL-720	Latch	2.00			EA		IA	N		
LJAMB	8000	Left Side Extrusion	1.00	1.0000		LI	H	IA	Y		8000
MISC	1X3/4X1/16	Glass Setting Blocks	4.00			EA		IA	N		1X3/4X1/16
MUNCLP	10946-002	Muntin Clips	1.00			EA		IA	N		10946-002
MUNTINH	536006	Muntin Bar Horizontl	1.00		3.5625	LI	W	IA	Y		536006
MUNTENV	536006	Muntin Bar Vertical	1.00	4.0000		LI	H	IA	Y		536006
RJAMB	8000	Right Side Extrusion	1.00	1.0000		LI	H	IA	Y		8000
SILL	8003	Bottom Extrusion	1.00		3.8750	LI	W	IA	Y		8003
TLTKEY	23110	Tilt Key	2.00		.0000	EA		IA	N		
WTSTPH	W432519W	Weather Strip (H)	2.00		3.8750	LI	W	IA	N		
WTSTPV	W432519W	Weather Strip (V)	4.00	1.2500		LI	H	IA	N		
-----											
End_of_Subassembly_IA *****											
ASSCR1	8X1-1/4FH	#8x1-1/4" PHFH Screw	4.00			EA		IB	N		
ASSCR2	6X1/2TRUSS	#6 X 1/2" PHPH Screw	2.00		.0000	EA		IB	N		
ASSCR3	8X1PH	#8 X 1" PHPH Screw	4.00			EA		IB	N		
GLASS	1CL	Default Glass Type	1.00	3.6250	3.0000	SF		IB	N		1CL
GLSSPC	SWGG-9/16	Glass Spacer	2.00		3.0000	LI	W	IB	N		SWGG-9/16
GLSSPC	SWGG-9/16	Glass Spacer	2.00	3.6250		LI	H	IB	N		SWGG-9/16

TEST SPECIMEN COMPLIES  
WITH THESE DETAILS.

ANY DEVIATION IS NOTED.

REPORT NO. NCTL-110-10910-1

TEST DATE: 9/20/2007

Bill of Materials Listing

Print Date: 9/27/07

Product: 8010

Type: DH

<---Deducts--->

Assembly Code	Part #	Description	Qty	Height	Width	Unit Code	Vert Hor	Sub Assy	Add Color	Fixed Length	W/Nailing Fin
HEADER	8004	Frame Top Extrusion	1.00		2.8750	LI	W	IB	Y		8004
LATCH	TWL-720	Latch	2.00			EA		IB	N		
LJAMB	8000	Left Side Extrusion	1.00	.7500		LI	H	IB	Y		8000
LOCK	VIG-3288	Lock	2.00			EA		IB	N		VIG-3288
MISC	1X3/4X1/16	Glass Setting Blocks	4.00			EA		IB	N		1X3/4X1/16
MUNCLP	10946-002	Muntin Clips	1.00			EA		IB	N		10946-002
MUNTNH	536006	Muntin Bar Horizontal	1.00		5.3750	LI	W	IB	Y		536006
MUNTNV	536006	Muntin Bar Vertical	1.00	4.0000		LI	H	IB	Y		536006
RJAMB	8000	Right Side Extrusion	1.00	.7500		LI	H	IB	Y		8000
SILL	8002	Bottom Extrusion	1.00		2.8750	LI	W	IB	Y		8002
-----											
TILTKEY	23110	Tilt Key	2.00			EA		IB	N		23110
VSWEEP	V-391	Vinyl Sweep	1.00		1.9375	LI	W	IB	Y		V-391
WTSTPH	W432519W	Weather Strip (H)	2.00		1.9375	LI	W	IB	N		
WTSTPV	W432519W	Weather Strip (V)	4.00	.8125	1.8750	LI	H	IB	N		
-----											
End of Subassembly IB *****											
ASSCR1	10X1TRUSS	#10 X 1" PHPH	8.00			EA		MF	N		10X1TRUSS
ASSCR2	10X5/8TRUSS	#10 X 5/8" PHPH	4.00			EA		MF	N		10X5/8TRUSS
BALSHO	7006T-LCK	Balance Shoes	4.00			EA		MF			7006T-LCK
HEADAD	VR-2180	Head Adapter Insert	1.00		1.9375	LI	W	MF	Y		VR-2180
HEADER	N-397	Frame Top Extrusion	1.00		.1250	LI	W	MF	Y		N-397
INSSTP	609	Insert Stop	1.00			EA		MF	Y	6.5000	609
JAMEXS	WOOD2	Jamb Extension	2.00	.0000		LI	H	MF			WOOD2
JAMEXT	WOOD2	Jamb Extension	2.00		1.2500	LI	W	MF			WOOD2
LJAMB	N-397	Left Side Extrusion	1.00	.0625		LI	H	MF	Y		N-397
MISC	5600CAP	Sill Bull Nose Cap	2.00			EA		MF	N		5600CAP
MISC	5600GUS	Sill Corner Gusset	2.00			EA		MF			5600GUS

TEST SPECIMEN COMPLIES  
WITH THESE DETAILS.

ANY DEVIATION IS NOTED.

REPORT NO. NCTL-110-10910-1

TEST DATE: 9/20/2007

Bill of Materials Listing

Print Date: Aug 17, 2007

Product: 8010... Type: DH

Assembly Code	Part #	Description	Qty	Height	Width	Unit Code	Vert Hor	Sub Assy	Add Color	Fixed Length	W/Nailing Fin
MISC	SRLABEL	Miscellaneous	1.00			EA		MF			SRLABEL
MISC	ERSCW006D4534	Jamb To Sill Pad	2.00			EA		MF			
MISC	42026	Aluminum Nailing Fin	1.00		.5000	LI	W	MF	N		
MISC	716	BlockNTackle Balance	4.00		.0000	EA		MF	N		
MISCLI	WRAP	Micellaneous	20.00			LI	W	MF			WRAP
RJAMB	N-397	Right Side Extrusion	1.00	-.0625		LI	H	MF	Y		N-397
SCAULK	896CTG789	Silicone Caulk	.20			EA		MF			896CTG789
SILL	M-402	Bottom Extrusion	1.00			LI	W	MF	Y		M-402
SILLTO	M-405	Sill Tower	1.00		1.8750	LI	W	MF	Y		M-405
WTSTPH	W432519W	Weather Strip (H)	1.00		-.1250	LI	W	MF	N		
-----											
End of Subassembly MF *****											
CKEYS	V6-611	Corner Keys	2.00			EA		SC	N		
CKEYS	V6-211	Corner Keys	2.00			EA		SC	N		
HEADER	V11BLWT3B	Frame Top Extrusion	1.00		3.8125	LI	W	SC	N		
LJAMB	V11BLWT3B	Left Side Extrusion	1.00	4.5000		LI	H	SC	N		
LSPRNG	V8-3769	Leaf Spring	4.00			EA		SC	N		
MISC	A-412	Plunger Spring	2.00			EA		SC	N		
MISC	74-151	Plastic Caps	2.00			EA		SC			
MISC	74-102	Plastic Plunger	2.00			EA		SC			
MISC	GA-817	Crossbar Clips	2.00			EA		SC			
RJAMB	V11BLWT3B	Right Side Extrusion	2.00	4.5000		LI	H	SC	N		
SCDEDF	1	Full Screen Deduct		4.0625	5.4375			SC			1
SCDEDH	1	Half Screen Deduct		.0625	4.5000			SC			1
SCLOTH	1816	Screen Cloth (Std)	1.00	.2500	4.6250	SF		SC	N		1816
SCLOTW	1816	Screen Cloth (Wire)	1.00			SF		SC	N		1816W
SILL	V11BLWT3B	Bottom Extrusion	1.00		3.7500	LI	W	SC	N		

TEST SPECIMEN COMPLIES  
WITH THESE DETAILS.

ANY DEVIATION IS NOTED.

REPORT NO. NCTL-110-10910-1

TEST DATE: 9/20/2007

Bill of Materials Listing

Print Date: 9/20/07

Product: 8010

Type: DH

<---Deducts--->

Assembly Code	Part #	Description	Qty	Height	Width	Unit Code	Vert Hor	Sub Assy	Add Color	Fixed Length	W/Nailing Fin
SSPLIN	.140	Screen Spline	2.00	.2500		LI	H	SC	N		
SSPLIN	.140	Screen Spline	2.00	.0000	4.2500	LI	W	SC	N		

-----  
End of Subassembly SC \*\*\*\*\*

TEST SPECIMEN COMPLIES WITH THESE DETAILS. ANY DEVIATION IS NOTED. REPORT NO. NCTL-110-109-10-1 TEST DATE: 9/20/2007

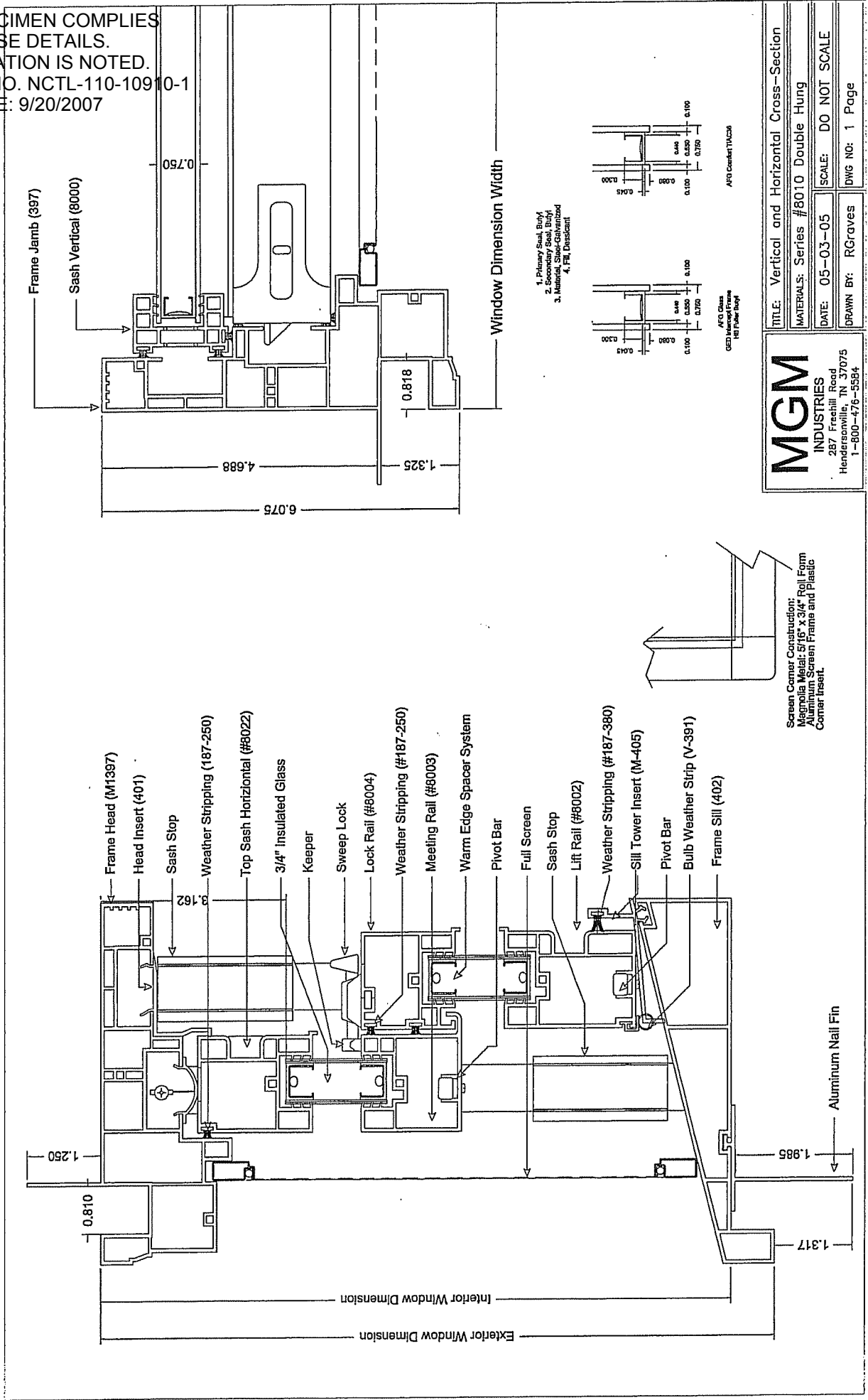

- 1. Primary Seal, Butyl
- 2. Secondary Seal, Butyl
- 3. Material, Steel-Coated/Anodized
- 4. Fin, Dissimilar

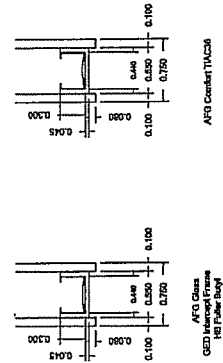

**MGM INDUSTRIES**  
 287 Fresh Hill Road  
 Hendersonville, TN 37075  
 1-800-476-5584

TITLE: Vertical and Horizontal Cross-Section  
 MATERIALS: Series #8010 Double Hung  
 DATE: 05-03-05 SCALE: DO NOT SCALE  
 DRAWN BY: RGraves DWG NO: 1 Page

Screen Corner Construction:  
 Magnolia Metal: 5/16" x 3/4" Roll Form  
 Aluminum Screen Frame and Plastic  
 Corner Insert

Aluminum Nail Fin

APPLICATION	REVISIONS		
NEXTEST SPECIMEN COMPACTS	REV.	DESCRIPTION	DATE   APPROVED

WITH THESE DETAILS.  
 ANY DEVIATION IS NOTED.  
 REPORT NO. NCTL-110-10910-1  
 TEST DATE: 9/20/2007

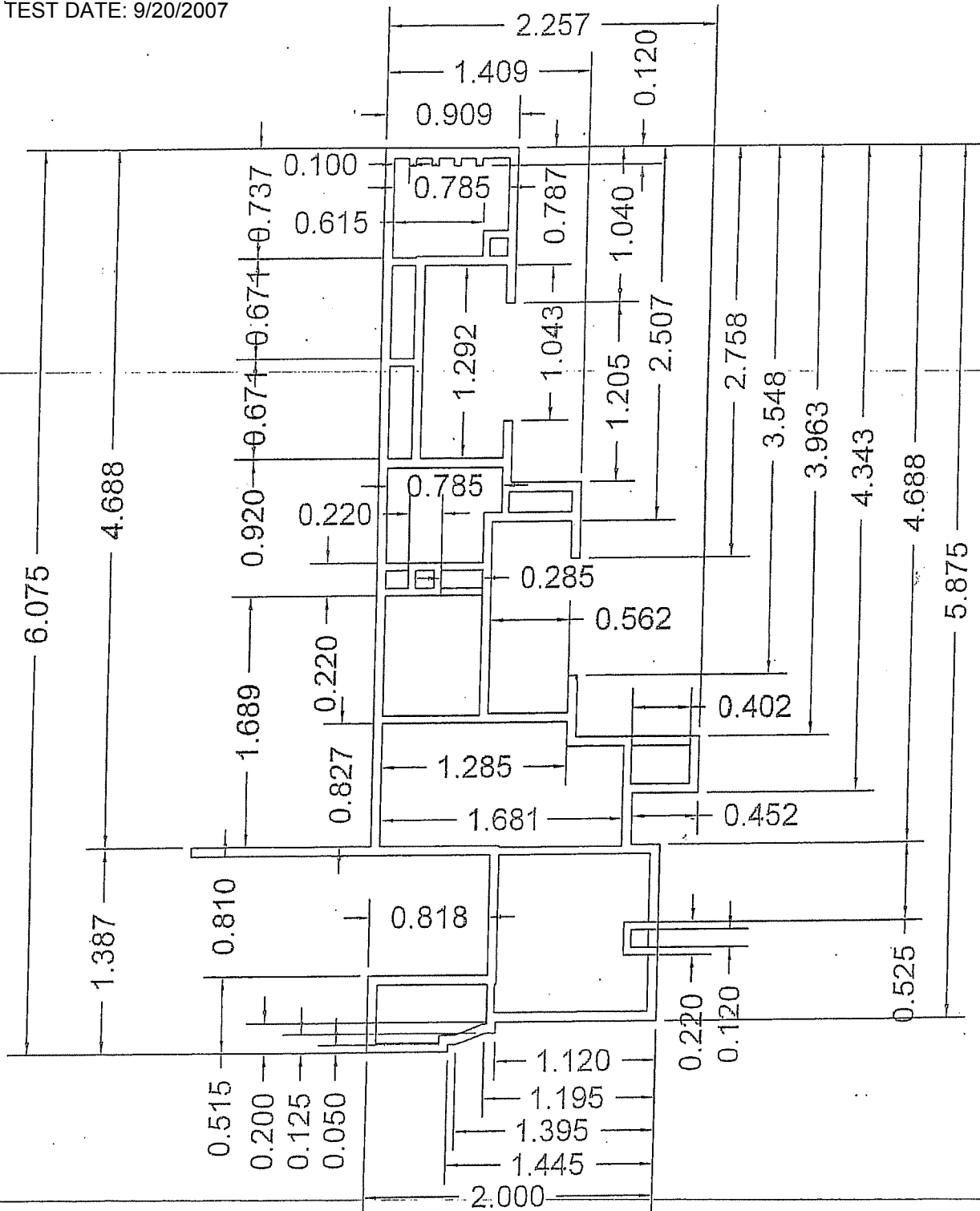

**IGM** INDUSTRIES

257 FREEHILL RD.  
 HENDERSONVILLE, TN  
 37075

ph 615-824-6572  
 fax 615-822-6581

DESCRIPTION: Series #8010-Double-Hung Main Frame

All walls .062, internal walls 0.050, radius corners .015, unless otherwise noted.

DO NOT SCALE DRAWING

REV.	DATE	BY
	03/02/05	R.Graves
WEIGHT	AREA	DWG.-NO.
1.0593		N-397

TEST SPECIMEN COMPLIES  
WITH THESE DETAILS.

ANY DEVIATION IS NOTED.

REPORT NO. ~~APPROXIMATE~~ 10910-1

REVISIONS

TEST DATE 9/20/2007

USED ON

REV.

DESCRIPTION

DATE

APPROVED

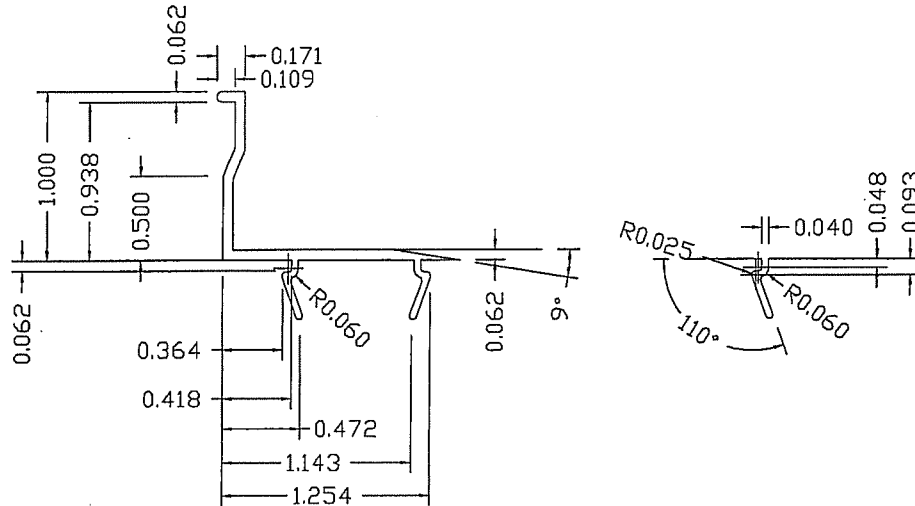

MGM INDUSTRIES  
287 FREEHILL ROAD  
HENDERSONVILLE, TN  
37075

615-824-6572  
DO NOT SCALE DRAWING

DESCRIPTION:  
Snap-in Header

DATE 09/20/04

ALL RADI TO BE 0.015  
ALL WALL THK TO BE  
0.062

WEIGHT  
0.109

AREA  
0.174

DWG. NO.  
M-401

REV.

BY: ABG

TEST SPECIMEN COMPLIES  
 WITH THESE DETAILS.  
 ANY DEVIATION IS NOTED.  
 REPORT NO. NCTL-110-10910-1  
 TEST DATE: 9/20/2007

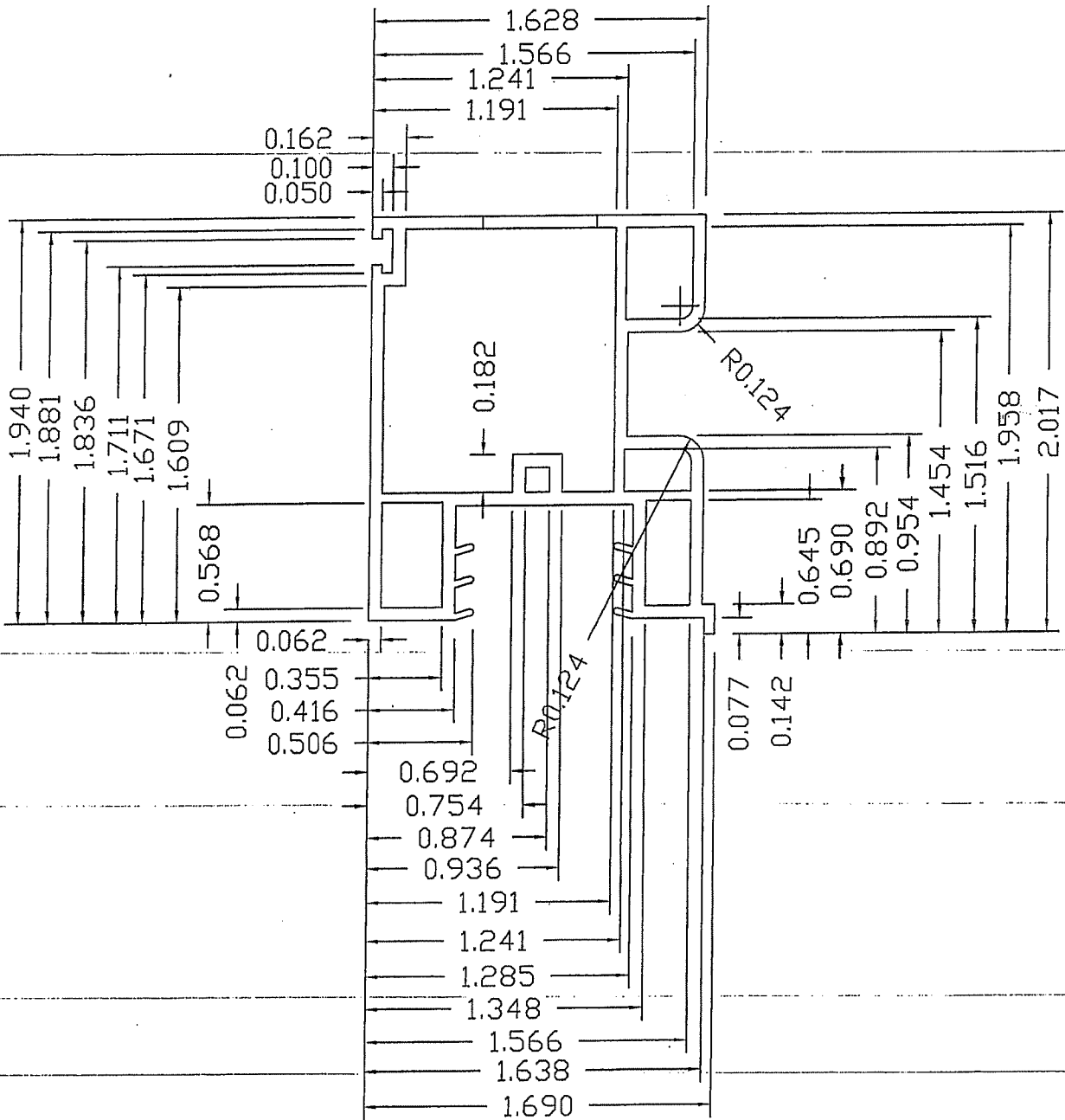
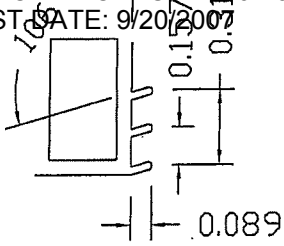

MGM INDUSTRIES 287 FREEHILL RD HENDERSONVILLE, TN 37075	DESCRIPTION:	ALL RADI TO BE 0.015. ALL WALL THK TO BE 0.062 UNLESS OTHERWISE SPECIFIED. INTERNAL WALLS 0.052 INTERNAL WALLS 0.052	DWG. NO.	REV.
	TOP SASH TOP RAIL		M-8022	
DATE 02/07/00	AREA	WT/FT	BY: ABG	

TEST SPECIMEN COMPLIES  
 WITH THESE DETAILS.  
 ANY DEVIATION IS NOTED.  
 REPORT NO. NCTL-110-10910-1  
 TEST DATE: 9/20/2007

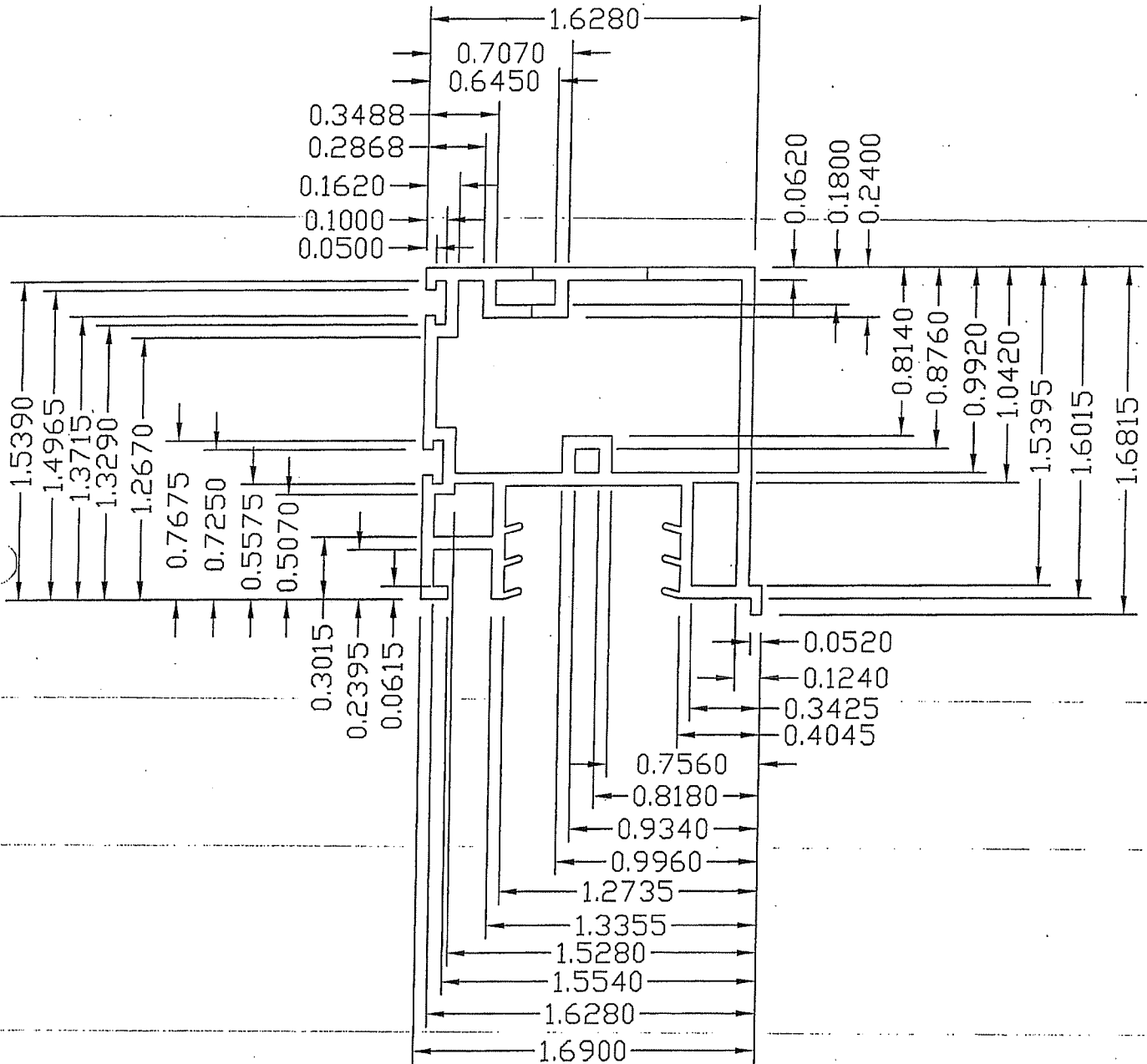

JGM INDUSTRIES 1287 FREEHILL RD HENDERSONVILLE, TN 37075	DESCRIPTION:	ALL RADI TO BE 0.015. ALL WALL THK TO BE 0.062 UNLESS OTHERWISE SPECIFIED. INTERNAL WALLS 0.052 INTERNAL WALLS 0.052	DWG. NO.	REV.
	BOTTOM SASH TOP RAIL		M-8004	1
DATE	02/07/00	AREA	.5932	WT/FT
			.3729	BY: ABG

TEST SPECIMEN COMPLIES  
 WITH THESE DETAILS.  
 ANY DEVIATION IS NOTED.  
 REPORT NO. NCTL-110-10910-1  
 TEST DATE: 9/20/2007

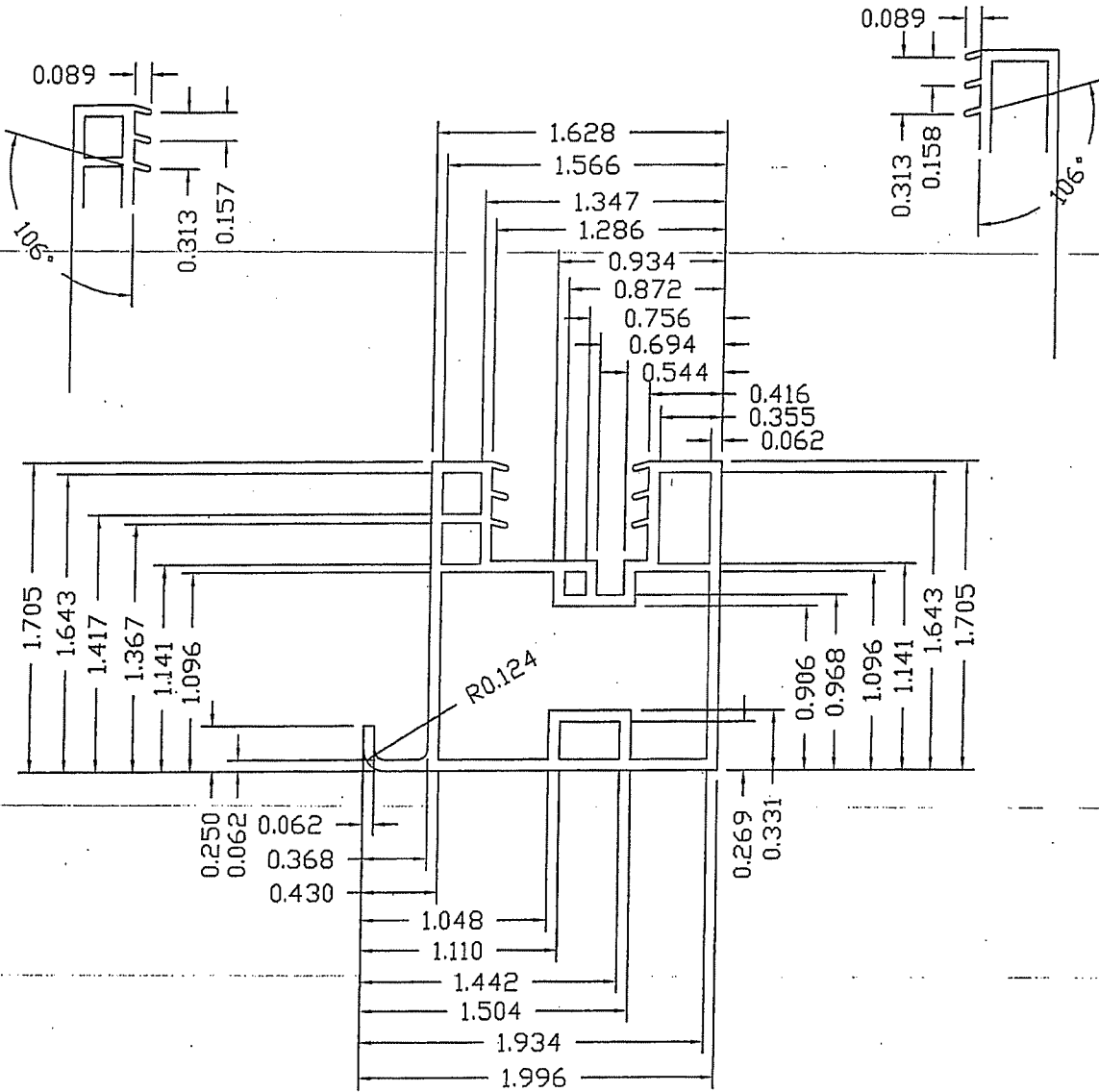

MGM INDUSTRIES 287 FREEHILL RD HENDERSONVILLE, TN 37075	DESCRIPTION:	ALL RADI TO BE 0.015. ALL WALL THK TO BE 0.0625 UNLESS OTHERWISE SPECIFIED. INTERNAL WALLS 0.052	DWG. NO. V-8003	REV. 2
	DO NOT SCALE	AREA .6232	WT/FT. 4.031	BY: ABG
	DATE 07/28/00			

TEST SPECIMEN COMPLIES  
 WITH THESE DETAILS.  
 ANY DEVIATION IS NOTED.  
 REPORT NO. NCTL-110-10910-1  
 TEST DATE: 9/20/2007

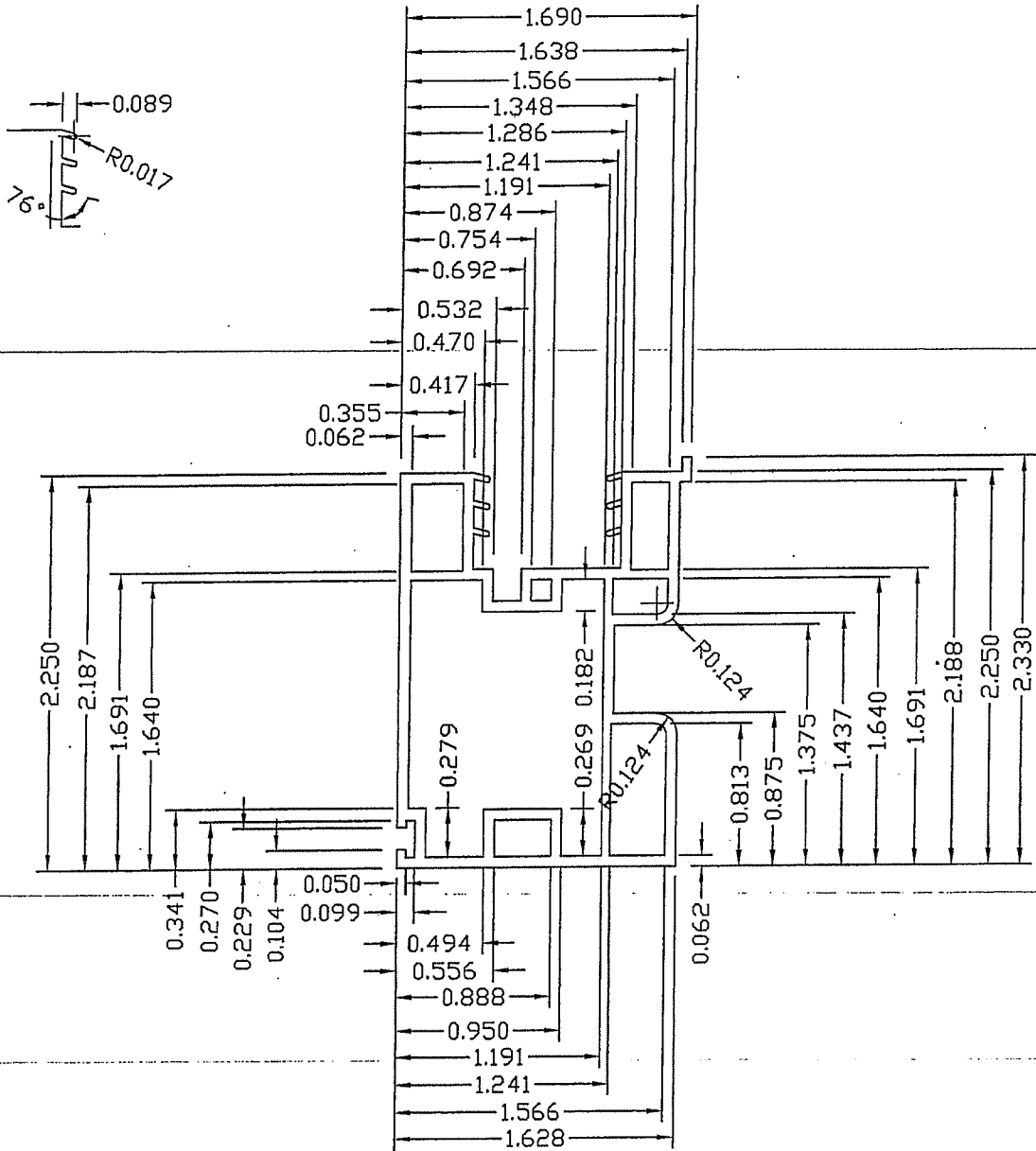

GM INDUSTRIES  
 287 FREEHILL RD  
 HENDERSONVILLE, TN  
 37075

DESCRIPTION:  
 Bottom sash  
 Bottom Rail

DATE  
 08/11/00

ALL RADI TO BE 0.015.  
 ALL WALL THK TO BE  
 0.0625 UNLESS  
 OTHERWISE SPECIFIED.  
 ALL INTERNAL RADI .052

DWG. NO.

V-8002

REV.

4

AREA

.7808

WT/FT

.4863

BY: ABG

TEST SPECIMEN COMPLIES WITH THESE DETAILS.  
 ANY DEVIATION IS NOTED.  
 REPORT NO. NCTL-110-10910-1  
 TEST DATE: 9/20/2007

REVISIONS

REV.	DESCRIPTION	DATE

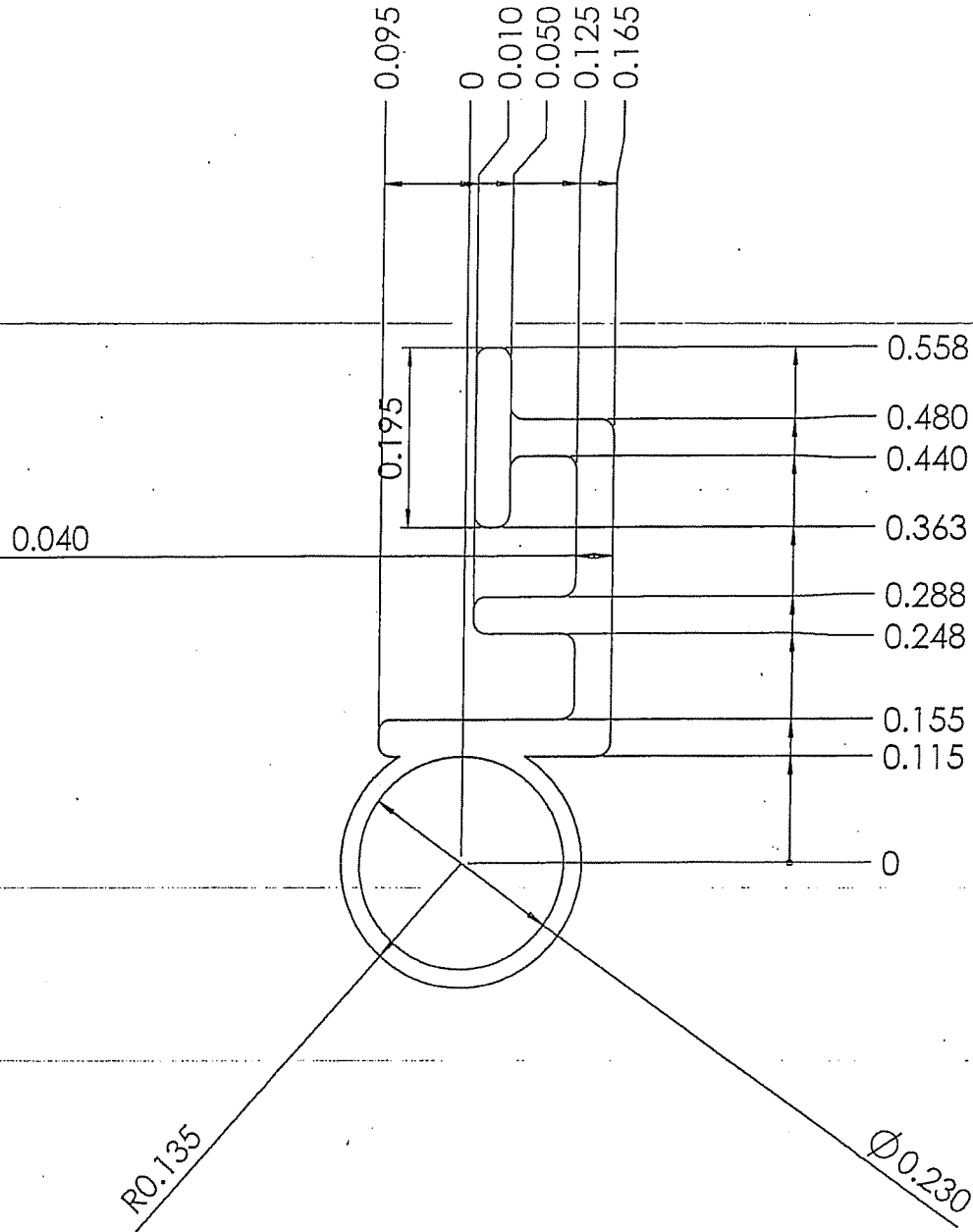

<b>MGM INDUSTRIES</b> 287 FREEHILL ROAD : HENDERSONVILLE, TN 37075 ph 615-824-6572 fax 615-822-6581 DO NOT SCALE DRAWING	DESCRIPTION:	ALL RAD TO BE 0.015	DWG. NO.	REV.
	Bulb Seal	ALL WALL THK TO BE 0.040 UNLESS OTHERWISE SPECIFIED	V-391	
DATE 12/06/02	WEIGHT	AREA	BY: ABG	

TEST SPECIMEN COMPLIES  
 WITH THESE DETAILS.  
 ANY DEVIATION IS NOTED.  
 REPORT NO. NCTL-110-10910-1  
 TEST DATE: 9/20/2007

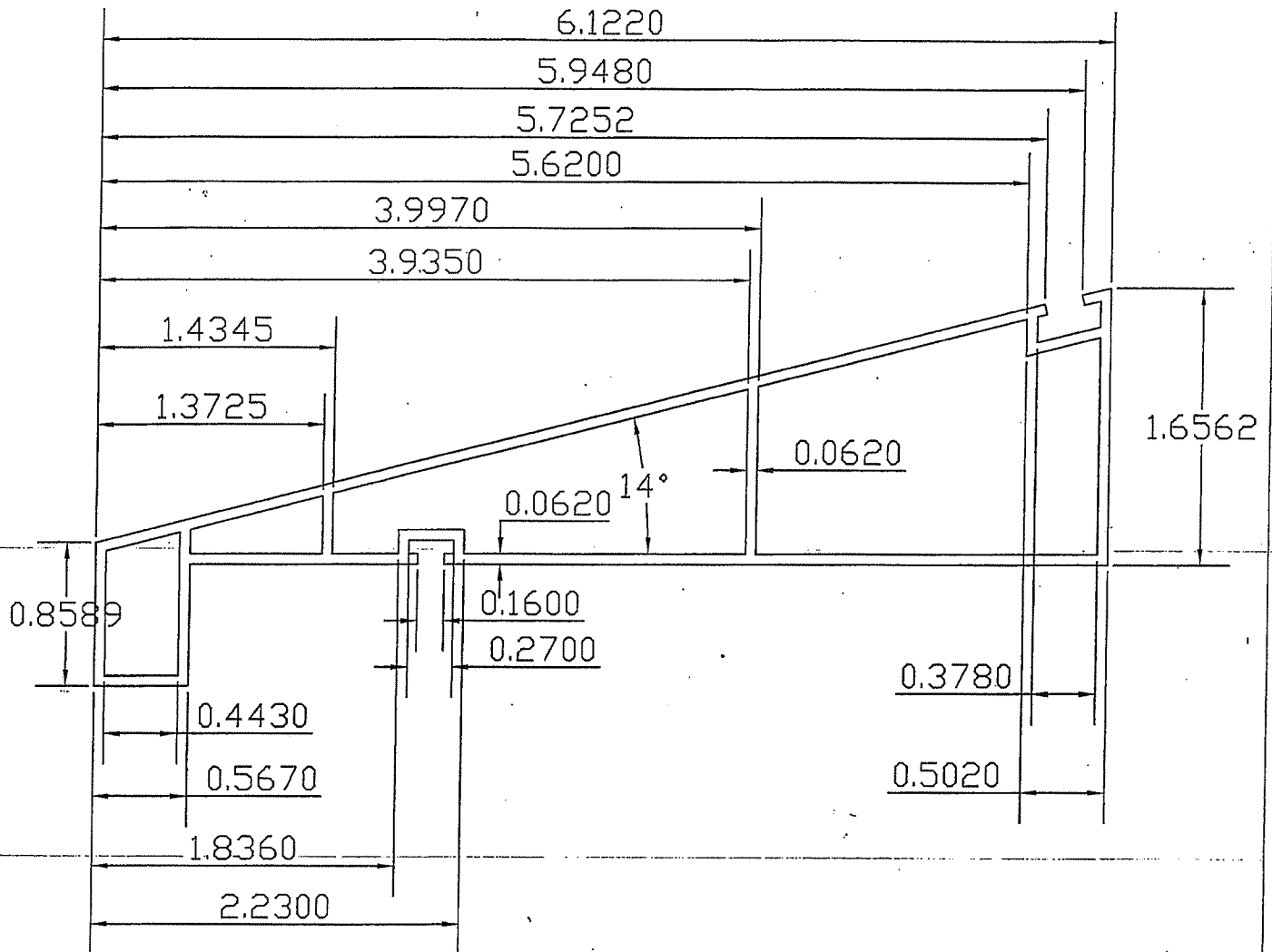

MGM INDUSTRIES 287 FREEHILL ROAD HENDERSONVILLE, TN 37075	DESCRIPTION:	ALL RADI TO BE 0.015 ALL WALL THK TO BE 0.062 UNLESS OTHERWISE SPECIFIED INTERNAL WALLS 0.050		DWG. NO.	REV.
	DATE	4 9/16 single Hung Sill	WEIGHT	M-402	BY: ABG
DO NOT SCALE DRAWING	07/07/03	0.6840	1.0962		

TEST SPECIMEN COMPLIES  
 WITH THESE DETAILS.  
 ANY DEVIATION IS NOTED.  
 REPORT NO. NCTL-110-10910-1  
 TEST DATE: 9/20/2007

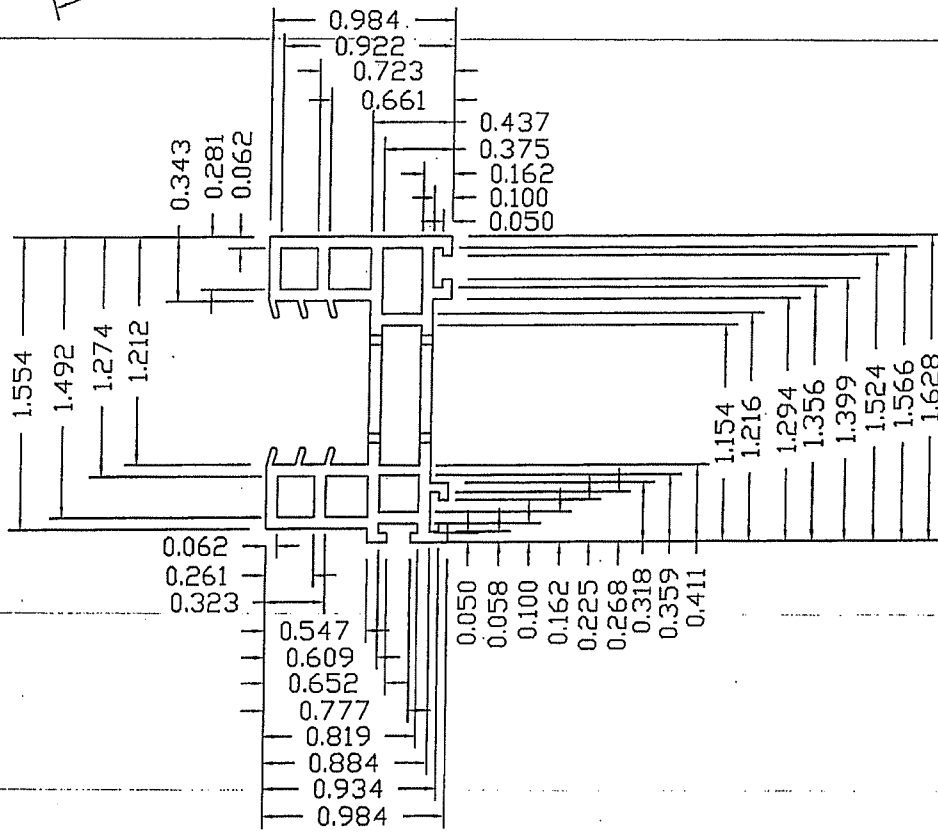
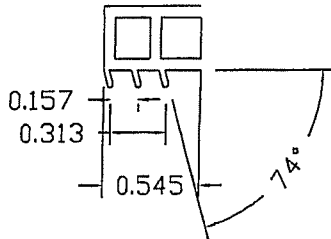

MGM INDUSTRIES  
 287 FREEHILL RD  
 HENDERSONVILLE, TN  
 37075

DESCRIPTION:  
 8000 Series Sash  
 DO NOT SCALE  
 DATE: 02/07/00

ALL RADI TO BE 0.015.  
 ALL WALL THK TO BE  
 0.0625 UNLESS  
 OTHERWISE SPECIFIED  
 AREA .4959  
 WT/FT .3094

DWG. NO. V-8000  
 REV. 1  
 DRAWN BY: R.Graves

APPLICATION TEST SPECIMEN COMPLIES WITH THESE DETAILS ON NEW TESTS. ANY DEVIATION IS NOTED. REPORT NO. NCTL-110-10910-1 TEST DATE: 9/20/2007	REVISIONS		
REV.	DESCRIPTION	DATE	APPROVED

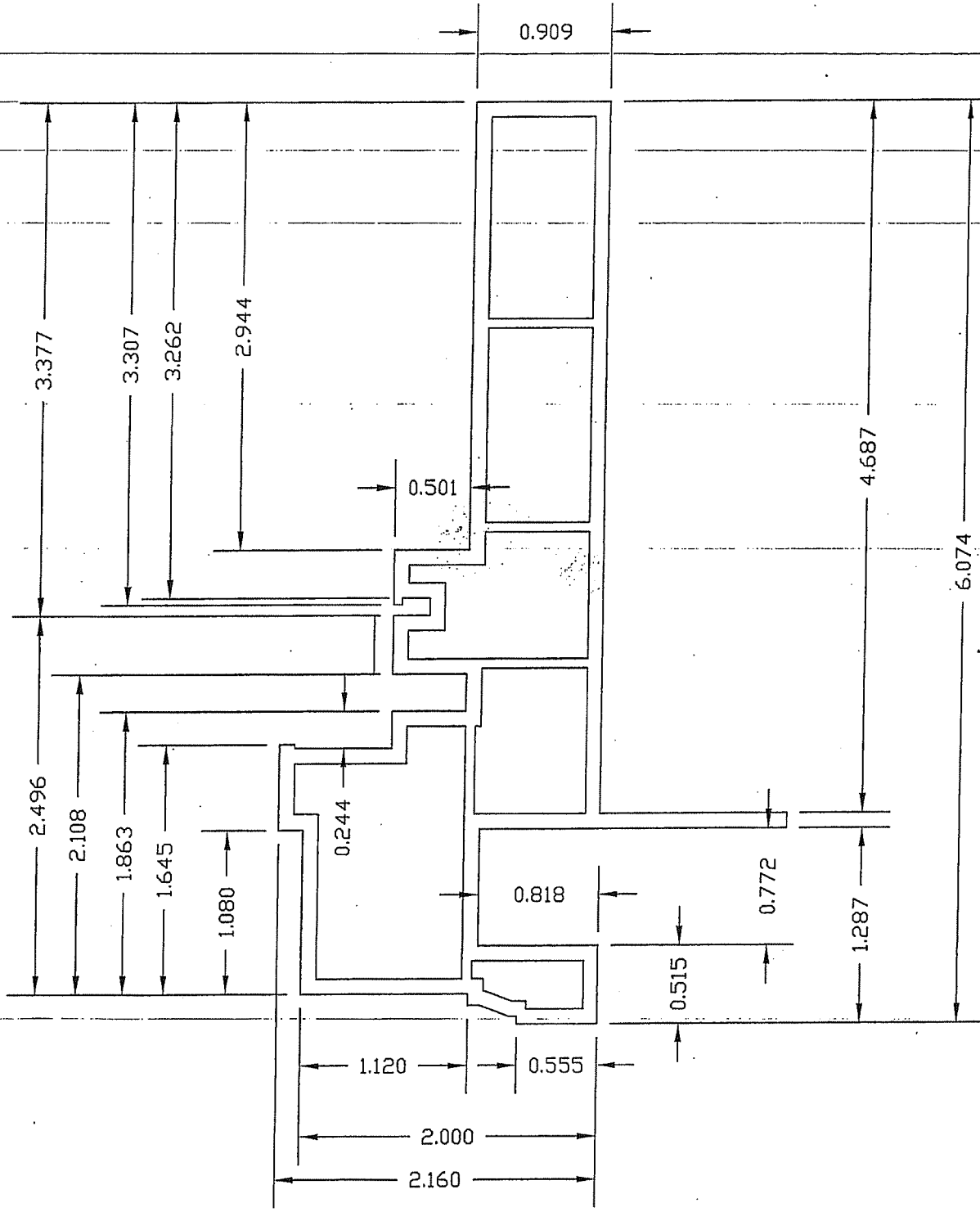

MGM INDUSTRIES 287 FREEHILL ROAD HENDERSONVILLE, TN 37075	DESCRIPTION: 4 11/16 Picture Window/Bending	ALL RADI TO BE 0.015 ALL WALL THK TO BE 0.100 UNLESS OTHERWISE SPECIFIED INTERNAL WALLS 0.062	DWG. NO. M-403	REV.
	DATE 07/07/03	WEIGHT 1.4142	AREA 2.2663	BY: ABG

DO NOT SCALE DRAWING

APPLICATION TEST SPECIMEN COMPLIES WITH ASSY DETAILS USED ON ANY DEVIATION IS NOTED. REPORT NO. NCTL-110-10910-1 TEST DATE: 9/20/2007	REVISIONS		
	REV.	DESCRIPTION	DATE APPROVED

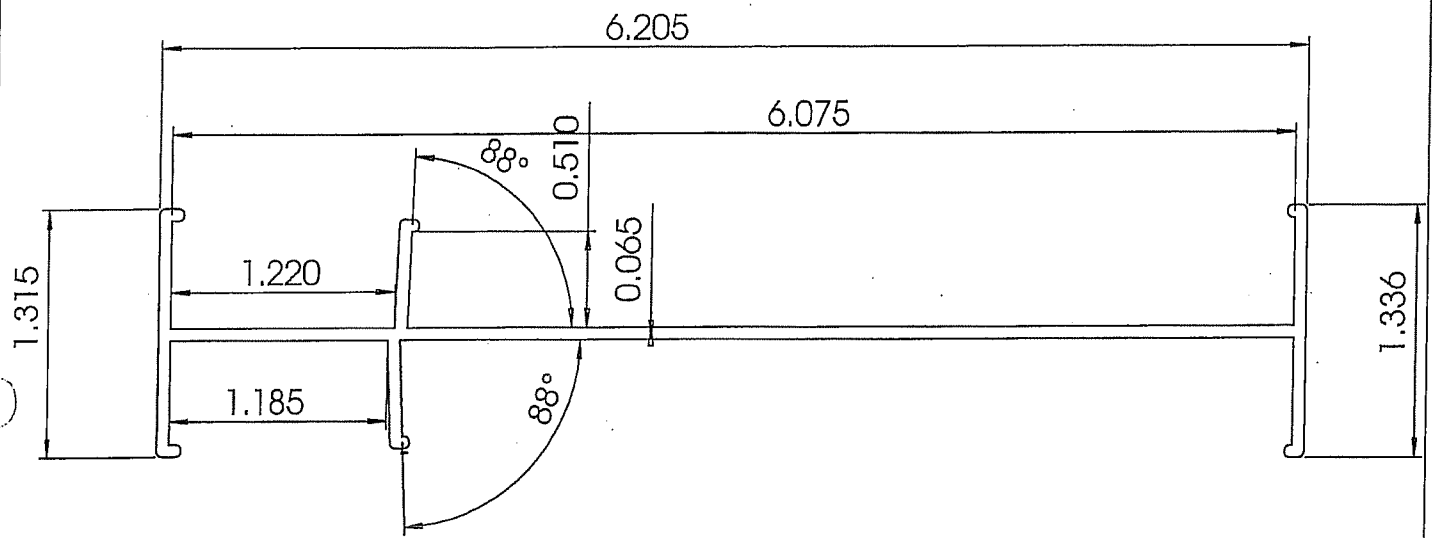

MGM INDUSTRIES 287 FREEHILL ROAD HENDERSONVILLE, TN 37075	DESCRIPTION: <b>Specials Mull for 5600 and 8006</b>	ALL RADI TO BE 0.015 ALL WALL THK TO BE 0.065 UNLESS OTHERWISE SPECIFIED INTERNAL WALLS 0.050	DWG. NO. <b>M-422</b>	REV. <b>1</b>
	DATE <b>05/03/04</b>	WEIGHT <b>0.410</b>	AREA <b>0.657</b>	BY: <b>ABG</b>
DO NOT SCALE DRAWING				

Revisions:

TEST SPECIMEN COMPLIES  
WITH THESE DETAILS.  
ANY DEVIATION IS NOTED.  
REPORT NO. NCT  
TEST DATE: 9/20/2007

EXPOSED

ACTUAL SIZE

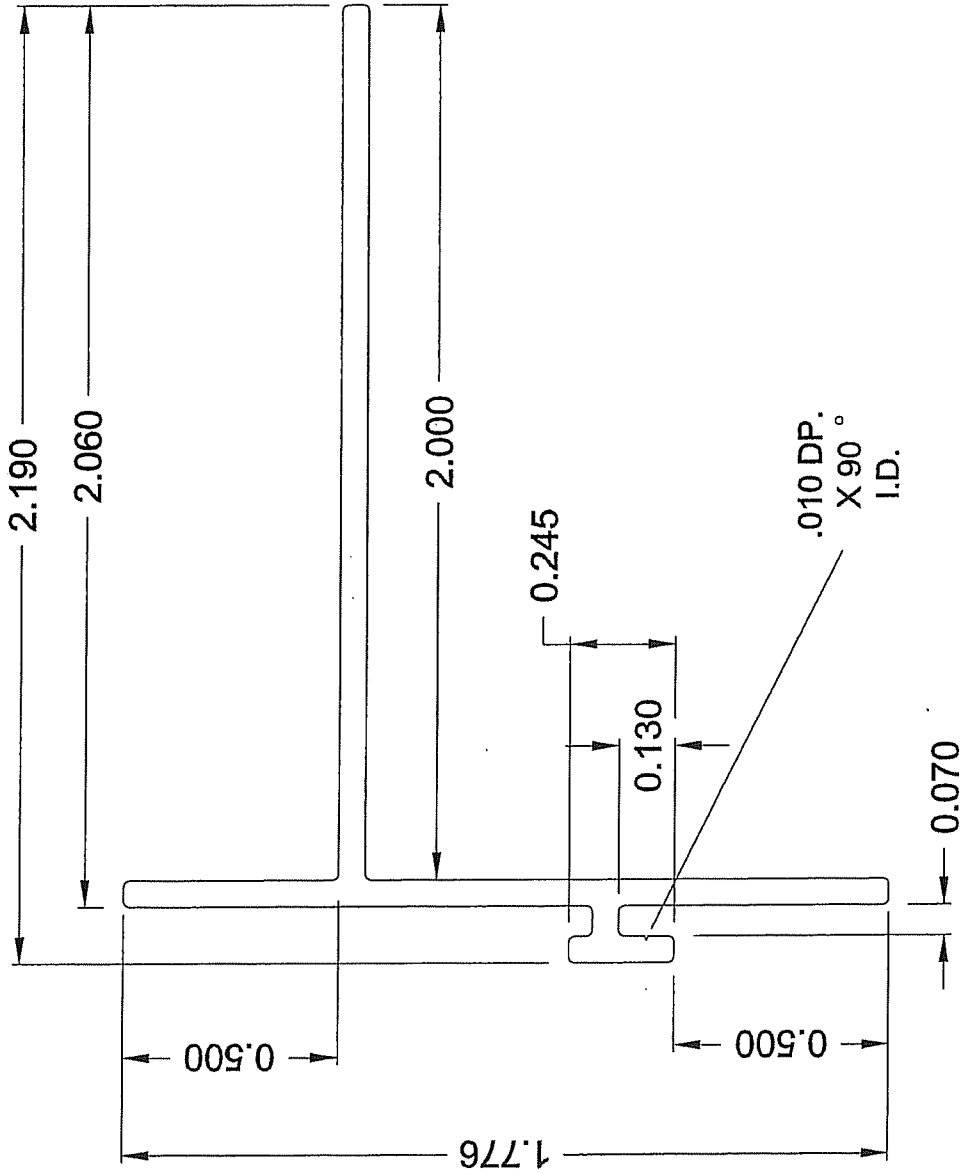

Unmarked Radii: .015		All Corners: .015		Radius Unless Specified:		Title: 8006 Nail Fin		Alloy/Temper: 6063-T6 Aluminum		Vendor Die Number: 22095 A	
INDUSTRIES, INC. 287 Freehill Road Hendersonville, Tennessee 37075 (615)-824-6572		8006 Nail Fin		Unspecified Wall Thickness: .060		Est. Area: .245		Scale: 2 X 1		Series#: 8000	
Vendor: Alcoa Extruded Construction Products		Est. Perimeter: 8.219		Est. Wt. Per Ft.: .294		BY: R. Graves		Date: 05/15/02		Customer #: A-127	
<b>MGM</b>											

TEST SPECIMEN COMPLIES  
 WITH THESE DETAILS.  
 ANY DEVIATION IS NOTED.  
 REPORT NO. NCTL-110-10910-1  
 TEST DATE: 9/20/2007

APPLICATION		REVISIONS			
NEXT ASSY.	USED ON	REV.	DESCRIPTION	DATE	APPROVED

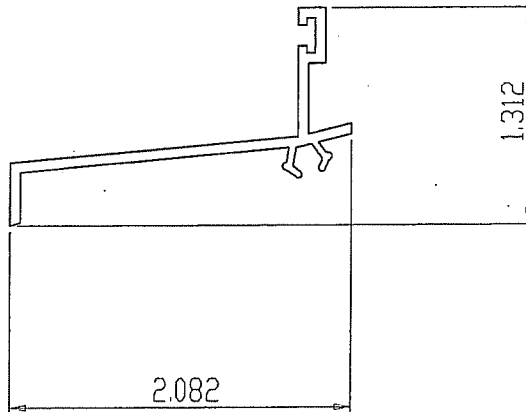

MGM INDUSTRIES 287 FREEHILL ROAD HENDERSONVILLE, TN 37075	DESCRIPTION: 8010 Sill Tower	ALL RADI TO BE 0.015 ALL WALL THK TO BE 0.062 UNLESS OTHERWISE SPECIFIED INTERNAL WALLS 0.050	DWG. NO. M-405	REV.
	DATE 01/01/01	WEIGHT 0.145	AREA 0.232	BY: ABG
DO NOT SCALE DRAWING				

TEST SPECIMEN COMPLIES  
 WITH THESE DETAILS.  
 ANY DEVIATION IS NOTED.  
 REPORT NO. NCTL-110-10910-1  
 TEST DATE: 9/20/2007

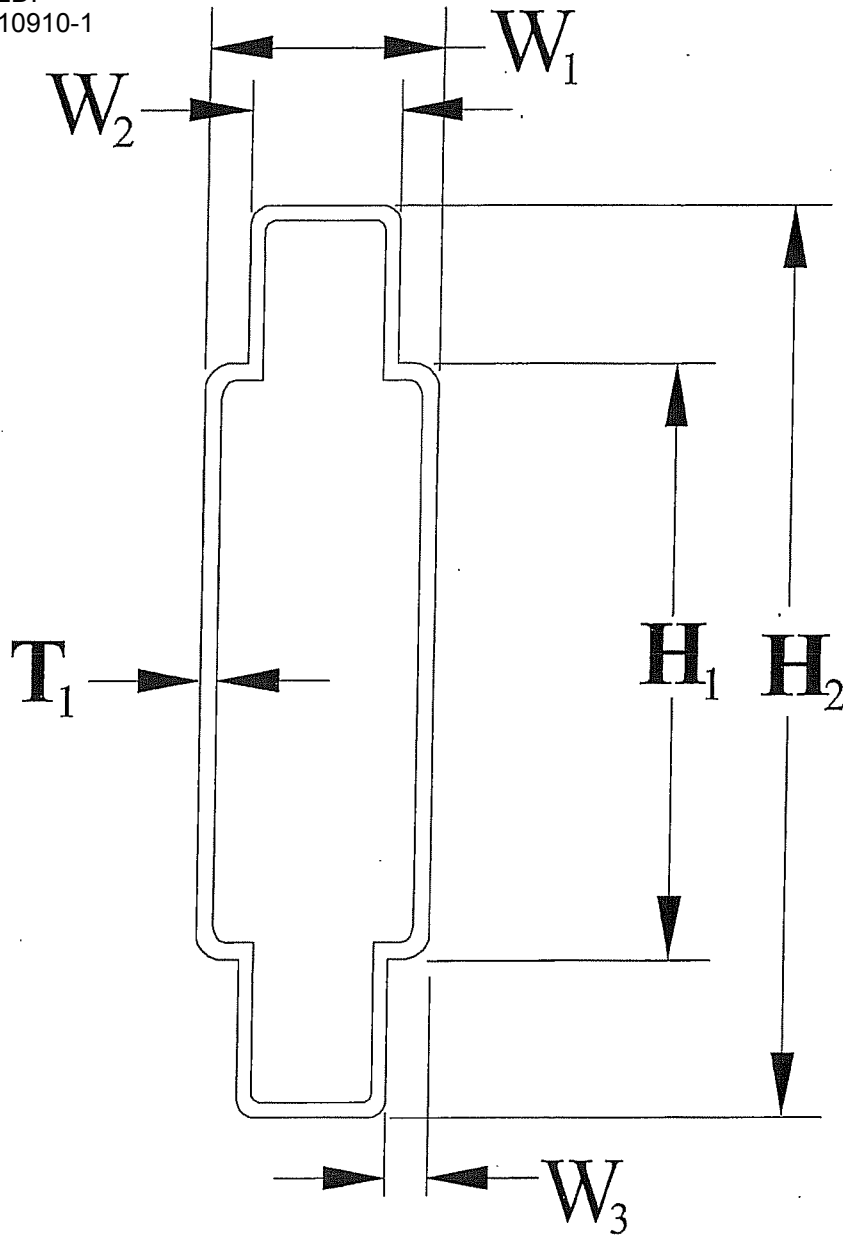

# Decorative

Divider Dimensions - Fill dimensions where applicable - Please fill out a divider sheet for each divider size used.

Dimensions			Material		
<input type="checkbox"/> $W_1$ <u>.1215</u> "	<input type="checkbox"/> $W_2$ <u>.1151</u> "	<input type="checkbox"/> $W_3$ <u>.064</u> "	<input type="checkbox"/> Aluminum	<input type="checkbox"/> Steel - Galvanized	<input type="checkbox"/> Other _____
<input type="checkbox"/> $H_1$ <u>.360</u> "	<input type="checkbox"/> $H_2$ <u>.715</u> "	<input type="checkbox"/> $T_1$ <u>.20</u> "	<input type="checkbox"/> Steel - Mild	<input type="checkbox"/> Steel - Stainless	

TEST SPECIMEN COMPLIES WITH THESE DETAILS. ANY DEVIATION IS NOTED.  
 REPORT NO. NCTL-110-10910-1  
 TEST DATE: 9/20/2007

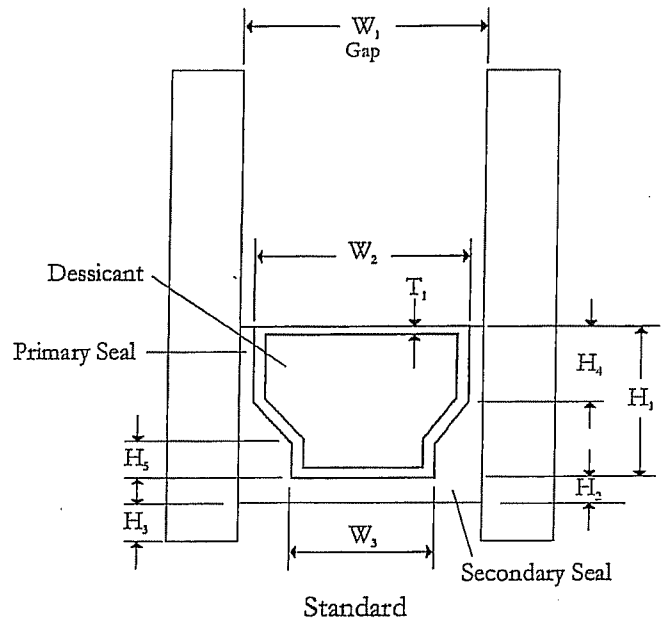
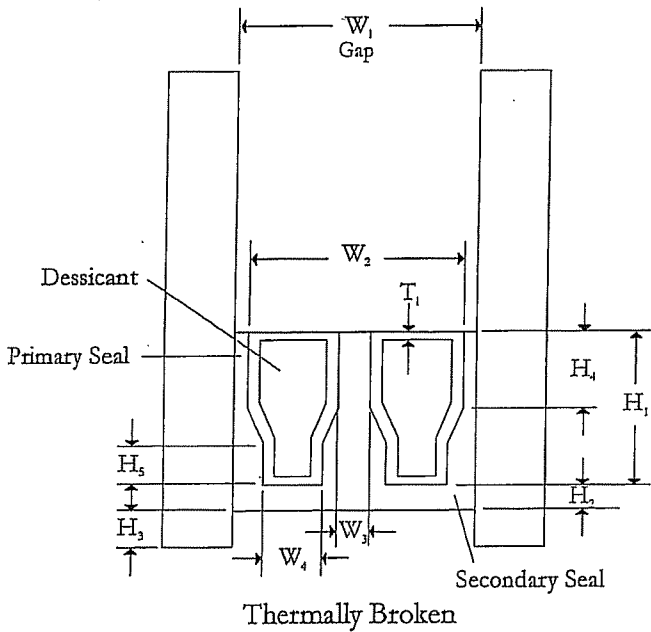
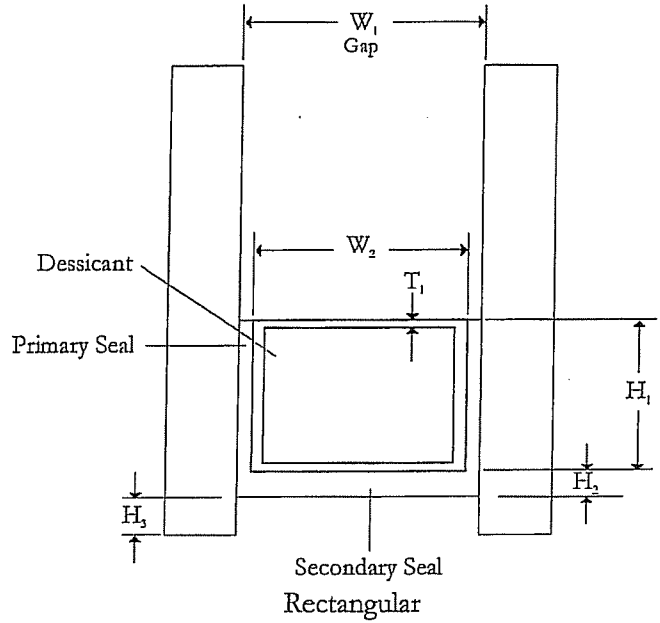
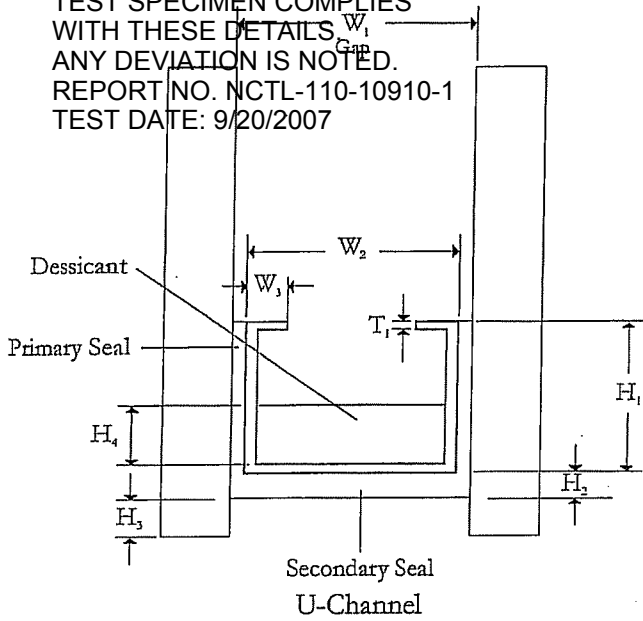

Spacer Dimensions - Fill dimensions where applicable - Please fill out a spacer sheet for each spacer used whether spacer type or size.

Gap	Primary Seal	Secondary Seal	Material	Fill
<input type="checkbox"/> W <sub>1</sub> <u>.451"</u>	<input checked="" type="checkbox"/> Butyl	<input checked="" type="checkbox"/> Butyl	<input type="checkbox"/> Aluminum	<input checked="" type="checkbox"/> Dessiccant
<input type="checkbox"/> W <sub>2</sub> <u>.405"</u>	<input type="checkbox"/> PIB	<input type="checkbox"/> PIB	<input type="checkbox"/> Steel - Mild	<input type="checkbox"/> Air
<input type="checkbox"/> W <sub>3</sub> <u>.070"</u>	<input type="checkbox"/> Polysulphide	<input type="checkbox"/> Polysulphide	<input type="checkbox"/> Steel - Stainless	<input type="checkbox"/> Other _____
<input type="checkbox"/> W <sub>4</sub> _____	<input type="checkbox"/> Silicone	<input type="checkbox"/> Silicone	<input checked="" type="checkbox"/> Steel - Galvanized	
<input type="checkbox"/> H <sub>1</sub> <u>.300"</u>	<input type="checkbox"/> Urethane	<input type="checkbox"/> Urethane	<input type="checkbox"/> Vinyl	
<input type="checkbox"/> H <sub>2</sub> <u>.045"</u>	<input type="checkbox"/> None	<input type="checkbox"/> None	<input type="checkbox"/> Foam _____	
<input type="checkbox"/> H <sub>3</sub> <u>.088"</u>	<input type="checkbox"/> Other _____	<input type="checkbox"/> Other _____	<input type="checkbox"/> Other _____	
<input type="checkbox"/> H <sub>4</sub> <u>.084"</u>				
<input type="checkbox"/> H <sub>5</sub> _____				
<input type="checkbox"/> T <sub>1</sub> <u>.1013"</u>				